

TAPS & SHOWERS TECHNICAL CRITERIA

Draft 20220202

1. Contents

| | |
|---|----|
| 2. SCOPE | 4 |
| 3. DEFINITIONS | 4 |
| 3.1. Tap | 4 |
| 3.2. Fixed shower | 4 |
| 3.3. Hand shower | 4 |
| 3.4. Shower Outlet | 4 |
| 3.5. Shower Solution | 4 |
| 3.6. Recirculating Shower Solution | 4 |
| 3.7. Electric Shower | 5 |
| 3.8. Aerator | 5 |
| 3.9. Supply Line Flow Regulator | 5 |
| 3.10. Cold water | 5 |
| 3.11. Hot water..... | 5 |
| 3.12. Boost Function..... | 5 |
| 3.13. Supply System Type 1..... | 6 |
| 3.14. Installation System Type 2..... | 6 |
| 4. TECHNICAL CRITERIA | 7 |
| 4.1. General | 7 |
| 4.2. Pressure systems | 7 |
| 4.3. Test Apparatus | 7 |
| 4.4. Rating classes | 8 |
| 4.5. Energy calculation - general | 8 |
| 4.6. Energy calculation – recirculating showers..... | 9 |
| 4.7. Use of Flow Regulators..... | 10 |
| 4.8. Instructions for use, maintenance, and replacement components..... | 10 |
| 5. General requirements | 11 |
| 5.1. Showers | 11 |
| 5.2. Recirculating showers | 11 |
| 5.3. Taps | 11 |
| 6. Shower outlets | 11 |

| | | |
|--------|---|----|
| 6.1. | Flow rate testing..... | 11 |
| 7. | Recirculating showers | 12 |
| 7.1. | Flow rate testing (non-recirculation mode)..... | 12 |
| 7.2. | Flow rate testing (recirculation mode)..... | 12 |
| 8. | Shower solutions..... | 13 |
| 9. | Electric Showers | 13 |
| 9.1. | Principle..... | 13 |
| 9.2. | Formula for flow rate calculation..... | 13 |
| 9.3. | Maximum available flow rate..... | 13 |
| 10. | Taps | 15 |
| 10.1. | Flow rate test..... | 15 |
| 11. | Supply Line Flow regulators & Aerators..... | 15 |
| 11.1. | Test procedure | 15 |
| 11.2. | Requirements | 15 |
| 12. | Functional test..... | 17 |
| 12.1. | Boost function | 17 |
| 12.2. | Cold start | 18 |
| 12.3. | Pressure independency | 18 |
| 12.4. | Sensor function | 19 |
| 12.5. | Spray Coverage..... | 19 |
| 12.6. | Spray dripping | 21 |
| 12.7. | Spray pattern..... | 22 |
| 12.8. | Thermostatic | 22 |
| 12.9. | Time flow..... | 22 |
| 12.10. | Water break..... | 23 |

2. SCOPE

This document defines the test procedures and requirements for the evaluation of energy and flow rate for taps, shower outlets, shower solutions, [recirculating shower solutions](#), electric showers and aerators for the listing on the Unified Water Label.

3. DEFINITIONS

3.1. Tap

Sanitary tapware designed to deliver water to the end user for various types of installation such as Kitchen taps, washbasin taps, bidets, combination taps, pillar taps. Including time flow or sensor operated products etc.

This scheme does not cover rating of taps or outlets that are designed only to deliver filtered, purified or 'boiling' water etc. for the specific use of making drinks.

3.2. Fixed shower

A shower which is fixed to a wall or ceiling, or part of a shower assembly. Fixed shower should be fixed in normal use.

3.3. Hand shower

A shower which is mainly held by hand or placed in a separate holder.

3.4. Shower Outlet

Any hand shower or fixed shower (excluding body or side jets).

3.5. Shower Solution

Shower solutions (also known as shower systems) shall be used to indicate the combination of a shower control (valve) complete with shower hose (flexible or rigid) and shower outlet.

3.6. Recirculating Shower Solution

A shower solution that recirculates water to be reused during a shower event. The example shown in [Figure 1](#) is for information purposes only.

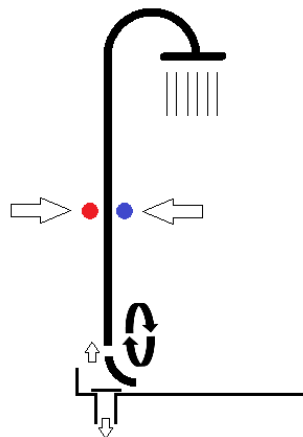

Figure 1: Recirculating shower system

3.7. Electric Shower

Showers that electrically heat the water as flow is opened. For the purposes of this Scheme all electric shower controls will comprise of a hand shower, flexible hose and shower heating unit.

3.8. Aerator

A device which is fitted at the outlet of a sanitary tapware product to impact the flow rate and stream appearance of the water stream.

A distinction is made between stream appearance:

- aerators without air intake, (known as “laminar” stream);
- aerators with air intake;
- Spray models (numerous single jets)

3.9. Supply Line Flow Regulator

A flow regulating device incorporating a flow regulator housed inside a dedicated fitting that may also include isolating valves and check valves as part of the design.

3.10. Cold water

Cold water has a temperature between 10 °C and 15 °C, for the use of tests detailed in this document

3.11. Hot water

Hot water has a temperature of cold water + 50 °C ±1 °C, for the use of tests detailed in this document

3.12. Boost Function

A device that temporarily allows an increase of flow rate that is automatically cancelled on closure of the flowcontrol

3.13. Supply System Type 1

Normally fed with high pressure water from the water distributors with a pressure range of (0,05 to 1,0) MPa [(0,1 to 10) bar]. Typical system is shown in *Figure 2*. Stored (hot) water is stored at pressure.

Key

- 1 Cold water
- 2 Hot water
- 3 Mains supply pipe (Supply pressures up to 10 bar)
- 4 Water heater

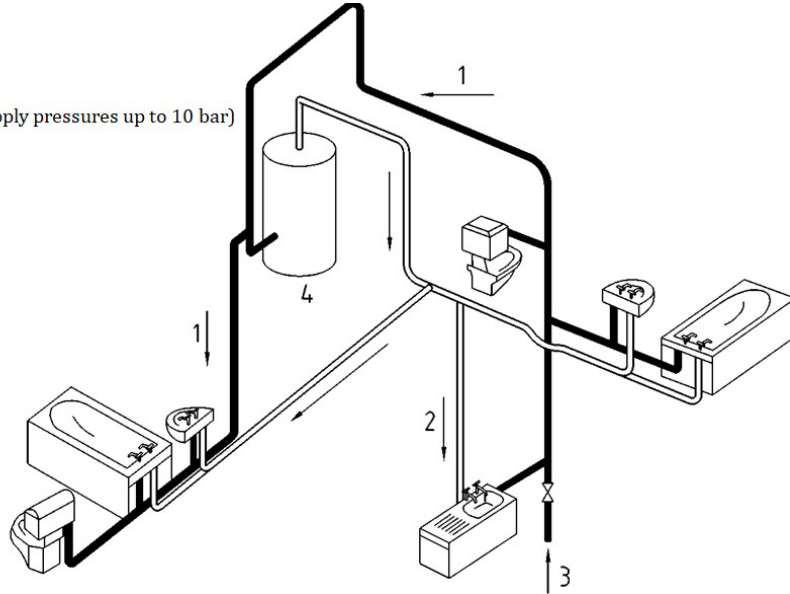

Figure 2: Type 1 supply system

3.14. Installation System Type 2

Normally fed with high pressure from the water distributors, but with a pressure range of (0,01 to 1,0) MPa [(0,5 to 10) bar]. Typical system is shown in *Figure 3*. Stored water (hot and sometimes cold) is supplied via a header tank and as such is stored at (relatively) low pressure

Key

- 1 Cold water storage cistern (cover omitted for clarity)
- 2 Warning pipe
- 3 Vent pipe
- 4 Hot water cylinder
- 5 Alternative cistern fed cold supply to sanitary appliances
- 6 To boiler
- 7 Mains supply pipe (Supply pressures up to 10 bar)

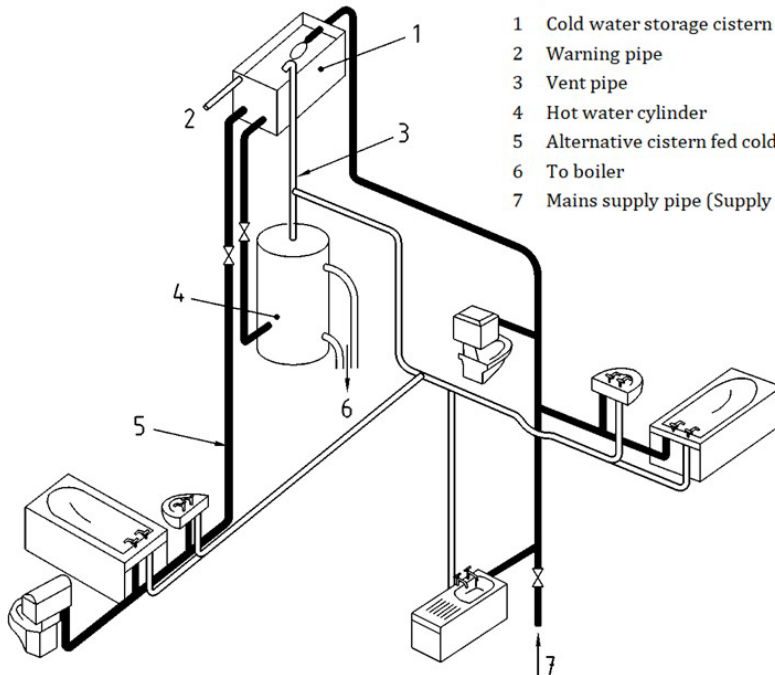

Figure 3: Type 2 supply system

4. TECHNICAL CRITERIA

4.1. General

The Unified Water Label (UWL) lists the maximum flow for registration into the scheme. Therefore, product performance tolerances can be no more than the stated performance.

Products submitted for approval shall comply with all relevant National Regulatory requirements of the country of intended destination.

Measurement equipment must be calibrated to (inter)National Standards e.g. ISO 9001 or similar.

4.2. Pressure systems

Where a product has the potential to be installed on Type 1 and Type 2 installations it shall be provided with suitable instructions directing the installer on how to install correctly to achieve the rated flow. If so desired, the manufacturer can choose to list the product for both Type settings on the scheme website and need to conduct tests accordingly.

| System | | Pressure (applied to each inlet) |
|--------|----|--|
| Type 1 | P1 | $(0,15_{-0}^{+0,01}) MPa$ $[(1,5_{-0}^{+0,1}) bar]$ |
| | P2 | $(0,3_{-0}^{+0,02}) MPa$ $[(3,0_{-0}^{+0,2}) bar]$ |
| Type 2 | P3 | $(0,01_{-0}^{+0,002}) MPa$ $[(0,1_{-0}^{+0,02}) bar]$ |

Table 1: Pressures and respective tolerances used during the different tests

4.3. Test Apparatus

Use for all tests a test apparatus which can deliver the pressures and tolerances given in *Table 1* and hot and cold water.

Note: Additional information can be found in the relevant EN product standards.

For recirculating showers, products shall be installed into a standard 90 x 90 shower enclosure and shower tray (2 x solid walls, 2,0 m high and a minimum of 500 mm free air above). The installation shall be acclimatised to 20 ± 2 °C for at least 24 hours prior to conducting tests.

4.4. Rating classes

Products will be rated according to their maximum recorded flow rate based on *Table 2* and recorded to one (1) decimal place.

| Class | Max. flow rate |
|-----------------------|----------------|
| 1 st class | ≤ 6.0 |
| 2 nd class | ≤ 8.0 |
| 3 rd class | ≤ 10.0 |
| 4 th class | ≤ 13.0 |
| 5 th class | > 13.0 |

Table 2: Flow rate classes

Note: - The classes detailed in *Table 2* will be translated into a suitable colour scheme for depiction in a label when listed on the UWL database.

4.5. Energy calculation - general

The energy used by an average user per year and product is provided on the label and calculated with:

| Fixed input values | Kitchen Tap | Basin Tap | Shower |
|---------------------------------|----------------|-----------|--------|
| Outlet temperature | 45 °C | 38 °C | 38 °C |
| Time per event (t) | 1 | 1 | 7 |
| Events per day (X) | 7 | 7 | 1 |
| Specific heat capacity of water | 4,18 kJ/(kg K) | | |
| Density of water | ≈0.981 kg/l | | |
| Inlet temperature | 15 °C | | |

Table 3: Fixed parameters for energy calculation

$$E_{label} \left[\frac{kWh}{annum} \right] = \frac{Q \left[\frac{l}{min} \right] \times 4,18 \left[\frac{kJ}{kg \times K} \right] \times (T_{out} - T_{in}) [K] \times 0,981 \left[\frac{kg}{l} \right]}{3600 \left[\frac{kJ}{kWh} \right]} \times t_{event} [min] \times X_{events} \left[\frac{1}{day} \right] \times 365 \left[\frac{day}{annum} \right]$$

Equation 1: Complete formula for energy calculation

Equation 1 can be reduced for each product with values from *Table 3* to:

$$E_{kitchen\ tap} \frac{kWh}{annum} \approx Q \left[\frac{l}{min} \right] \times 87,3082 \left[\frac{kWh \times min}{annum \times 1} \right]$$

Equation 2: Short energy calculation for kitchen taps

$$E_{basin\ tap} \frac{kWh}{annum} \approx Q \left[\frac{l}{min} \right] \times 66,9363 \left[\frac{kWh \times min}{annum \times 1} \right]$$

Equation 3: Short energy calculation for basin taps

$$E_{shower} \frac{kWh}{annum} \approx Q \left[\frac{l}{min} \right] \times 66,9363 \left[\frac{kWh \times min}{annum \times 1} \right]$$

Equation 4: Short energy calculation for showers

4.6. Energy calculation – recirculating showers

For recirculating showers, the energy consumption from pumps, UV filters, heating elements, etc., shall also be factored into the total energy calculation.

4.6.1. Non-recirculation mode

The calculation for recirculating showers in non-recirculation mode follows the same formula as for traditional showers with the addition of E_{power} and E_{rinse} (where appropriate):

$$E_{label} \left[\frac{kWh}{annum} \right] = \frac{Q \left[\frac{l}{min} \right] \times 4,18 \left[\frac{kJ}{kg \times K} \right] \times (T_{out} - T_{in}) [K] \times 0,981 \left[\frac{kg}{l} \right]}{3600 \left[\frac{kJ}{kWh} \right]} \times t_{event} [min] \times X_{events} \left[\frac{1}{day} \right] \times 365 \left[\frac{day}{annum} \right] + E_{power} \left[\frac{kWh}{annum} \right] + E_{rinse} \left[\frac{kWh}{annum} \right]$$

Equation 5: Complete formula for energy calculation of recirculating showers in non-recirculating mode

The addition of E_{power} is calculated as follows with P_W recorded with the recirculating shower running in “steady state” conditions:

$$E_{power} \left[\frac{kWh}{annum} \right] = \left(\frac{P_W \times t_{hours}}{1000} \right) \div 60 \left[\frac{min}{hour} \right] \times t_{event} [min] \times X_{events} \left[\frac{1}{day} \right] \times 365 \left[\frac{day}{annum} \right]$$

Equation 6: Formula for power consumption

The addition of E_{rinse} is calculated as follows:

$$E_{rinse} \left[\frac{kWh}{annum} \right] = \frac{Qh \left[\frac{l}{min} \right] \times 4,18 \left[\frac{kJ}{kg \times K} \right] \times (T_{out} - T_{in}) [K] \times 0,981 \left[\frac{kg}{l} \right]}{3600 \left[\frac{kJ}{kWh} \right]} \times t_{event} [min] \times X_{events} \left[\frac{1}{week} \right] \times 52 \left[\frac{week}{annum} \right] + E_{power} \left[\frac{kWh}{annum} \right]$$

Equation 7: Formula for power consumption during rinse function

Equation 5 can be reduced for recirculating showers in non-recirculation mode with values from Table 3 to:

$$E_{recirc (non) shower} \frac{kWh}{annum} \approx \left(Q \left[\frac{l}{min} \right] \times 66,9363 \left[\frac{kWh \times min}{annum \times 1} \right] \right) + E_{power} + E_{rinse}$$

Equation 8: Short energy calculation for recirculating showers in non-recirculating mode

4.6.2. Recirculation mode

The calculation for recirculating showers in recirculation mode follows the same formula principle as for traditional showers with the addition of E_{power} and E_{rinse} and taking account only of the HW supply:

$$E_{label} \left[\frac{kWh}{annum} \right] = \frac{Qh \left[\frac{l}{min} \right] \times 4,18 \left[\frac{kJ}{kg \times K} \right] \times (T_h - T_c) [K] \times 0,981 \left[\frac{kg}{l} \right]}{3600 \left[\frac{kJ}{kWh} \right]} \times t_{event} [min] \times X_{events} \left[\frac{1}{day} \right] \times 365 \left[\frac{day}{annum} \right] + E_{power} \left[\frac{kWh}{annum} \right] + E_{rinse} \left[\frac{kWh}{annum} \right]$$

Equation 9: Complete formula for energy calculation of recirculating showers in recirculating mode

Equation 9 can be reduced for recirculating showers in non-recirculation mode with values from Table 3 to:

$$E_{recirc shower} \frac{kWh}{annum} \approx \left(Qh \left[\frac{l}{min} \right] \times 145,5136 \left[\frac{kWh \times min}{annum \times 1} \right] \right) + E_{power} + E_{rinse}$$

Equation 10: Short energy calculation for recirculating showers in recirculating mode

4.7. Use of Flow Regulators

Where products are supplied with one or more flow regulator 'in the box' then the product can be tested and listed as a low-pressure product with testing conducted at the appropriate declared maximum working pressure (or 0.1 bar); or the product is tested and listed as if the flow regulators were fitted to the product.

Where this is the case suitable instructions in the installation guide must be included to ensure that the configuration that is listed on the scheme is adequately described to enable the declared flow rate to be achieved.

4.8. Instructions for use, maintenance, and replacement components

Testing with a dedicated shower hose and dedicated shower outlet means that in the event of a shower hose or shower outlet having to be replaced, the components must be replaced on a like for like basis. Failure to do so may create a safety hazard and the requirements of the scheme may no longer be satisfied - and listing invalidated. This must be made clear within the installation and maintenance instructions.

5. General requirements

5.1. Showers

Showers must meet the following requirements:

- Maximum available flow rate
- Pressure independency (for Type 1 products delivering the maximum flow rate ≤ 8.0 l/min)
- Spray coverage
- Spray pattern
- Spray dripping (for hand showers)

Note: If a shower outlet has more than one mode, at least one of the modes, as specified by the manufacturer, must meet the requirements for pressure independency (where applicable) and spray coverage while the maximum available flow may require a different mode.

5.2. Recirculating showers

- Backflow protection shall be provided using appropriate devices referenced in EN 1717.
- When in standby mode, power consumption shall not exceed 0,5 W (TBC)

When in recirculating mode, recirculating showers must meet the following requirements:

- Maximum total water volume per showering event
- Spray coverage
- Spray pattern
- Spray dripping (for hand showers)

Note: If a recirculating shower outlet has more than one mode, at least one of the modes, as specified by the manufacturer, must meet the requirements for spray coverage while the maximum total water volume per showering event may require a different mode.

5.3. Taps

Taps must meet the following requirements:

- Maximum available flow rate
- Pressure independency (for Type 1 products delivering ≤ 8.0 l/min)

6. Shower outlets

6.1. Flow rate testing

5.1.1 Procedure

1. Connect the shower outlet to the test apparatus
2. Adjust the shower plate horizontally facing downwards
3. Make sure that pressure P2 is reached at the center of the face plate of the shower outlet
4. Report flow rate Q after stabilization

Note: If the showerhead has more than one mode, the mode with the highest flow rate is used to determine the flow rate. Note2: Pressure loss between shower plate and inlet can be approximated by 0,1 bar per meter height difference.

5.1.2 Maximum available flow rate

The maximum flow rate (Q_{max}) shall be listed on the labelling scheme.

7. Recirculating showers

Recirculating showers are installed 'as delivered' and in accordance with the manufacturer's instruction, connected to the test apparatus and each shower outlet is tested afterwards. Testing is performed at $38^{\circ}\text{C} \pm 1^{\circ}\text{C}$.

7.1. Flow rate testing (non-recirculation mode)

7.1.1. Procedure

1. Connect the recirculating shower to the test apparatus
2. Adjust the shower plate horizontally facing downwards
3. Ensure that the recirculating shower is not in recirculation mode
4. Apply pressure P2
5. Report flow rate Q after stabilization

Note: If the showerhead has more than one mode, the mode with the highest flow rate is used to determine the flow rate.

7.1.2. Maximum available flow rate

The maximum flow rate (Q_{max}) shall be listed on the labelling scheme.

7.2. Flow rate testing (recirculation mode) *To be discussed further*

7.2.1. Procedure

1. Connect the recirculating shower to the test apparatus
2. Adjust the shower plate horizontally facing downwards
3. Ensure that the recirculating shower is in recirculation mode
4. Apply pressure P2
5. Commence measurement of the water volume *from the waste outlet*
6. After stabilization, measure the flow rate delivered to the user

Method to be determined:

- in-line flow meter to showerhead - cannot restrict flow

- collecting discharge not possible (will affect product recirculating)

- other ??

- don't test, i.e., assume that max flow rate is the same as non-recirc mode?

7. After 7 minutes turn off the shower, for showers with a cleaning / rinse function refer to 7.2.2
8. Divide the total water consumption by 7 and report the flow rate Q

Note: If the showerhead has more than one mode, the mode with the highest flow rate is used to determine the flow rate.

7.2.2. Cleaning / rinse function

1. In case the recirculating shower has a cleaning / rinse function after shut-off continue to measure the water volume used
2. Report the total water volume used for the 7-minute shower event, plus the water volume used for any cleaning / rinse function, divide the total water consumption by 7 and report the flow rate Q

Note: If the recirculating shower does not perform the cleaning / rinse function after every shower event, the frequency as per the factory default shall be used and factored into the calculation.

Note: If the cleaning / rinse function is not performed automatically, the manufacturer shall state the

recommended frequency within the instructions for use, which shall be used and factored into the calculation.

7.2.3. Maximum available flow rate

The maximum flow rate ($Q_{max R}$) shall be listed on the labelling scheme in addition to the maximum flow rate (Q_{max}) determined in 7.1.1

8. Shower solutions

Shower solutions are installed 'as delivered' and in accordance with the manufacturer's instruction, connected to the test apparatus and each shower outlet is tested afterwards. Each shower of a shower system can be listed and marked separately e.g., hand shower and fixed shower, if only one flow rate is listed/labeled: the maximum flow rate of all included shower outlets must be listed/labeled.

Flow rate is tested according to shower outlets (see 6).

9. Electric Showers

9.1. Principle

Electric showers deliver hot water at a flow rate as a function of their design primarily based upon the power rating of the heating element. The flow rate is further affected by incoming water temperature and the desired set temperature of the outlet water. The relationship of all these factors is identical for all designs of electric showers. Physical testing is therefore not needed to validate the flow rates of these products.

9.2. Formula for flow rate calculation

For the purposes of this Scheme, adjusted values from *Table 4* are used:

| | |
|---------------------------------|----------------|
| Outlet temperature | 42 °C |
| Inlet temperature | 15 °C |
| Operating voltage | 240 V |
| Density of water | ≈1 kg/l |
| Specific heat capacity of water | 4,18 kJ/(kg K) |

Table 4: Fixed parameters for flow rate calculation

$$Q \left[\frac{l}{min} \right] = 60 \left[\frac{s}{min} \right] \times \left(\frac{P_{electric\ shower} [kW]}{4,18 \left[\frac{kJ}{kg \times K} \right] \times (T_{out} - T_{in})} \right) \times 1 \left[\frac{kg}{l} \right]$$

Equation 11: Calculation of flow rate for electrical showers

With parameters from *Table 4*, the flow rate calculation from *Equation 11* is reduced to:

$$Q_{max} \left[\frac{l}{min} \right] \approx 0,532 \times P_{electric\ shower} [kW]$$

Equation 12: Short flow rate calculation

9.3. Maximum available flow rate

The maximum flow rate (Q_{max}) shall be listed on the labelling scheme.



Figure 4: Efficient label

10. Taps

10.1. Flow rate test

10.1.1. Procedure

1. Connect the tap to the test apparatus in its condition of use
2. Apply pressure P2
3. Fully open the flow control device(s)
4. Record the flow rate Q

10.1.2. Maximum available flow rate

The maximum flow rate (Q_{max}) shall be listed on the labelling scheme.

11. Supply Line Flow regulators & Aerators

In terms of this scheme, these products are designed to be repair and replacement components for existing products and, where possible retrofit products to existing sanitary tapware not originally fitted with flow regulated outlets.

It is the case that the whole design of sanitary tapware product has an influence on the final flow rate. As such, the flow rate of a listed aerator cannot be taken as the value for sanitary tapware to list or obviate the need to list in their own right sanitary tapware products.

11.1. Test procedure

For the test, a sample of the aerators with incorporated flow regulators shall be tested. The following test sequence shall be used:

Assemble the test piece with the appropriate adapter as detailed in figure 5 of prEN 246;

1. Adjust the supply circuit to deliver a constant dynamic pressure P2;
2. To preload/condition the test piece, allow water to flow for (30 -0/+5) seconds;
3. Reduce the water supply to (0,5 -0/+0,2) bar for (30 -0/+5) seconds;
4. Re-open the water supply and adjust the dynamic pressure to P1;
5. After the pressure adjustment, allow the water to flow for (30 -0/+1) seconds;
6. Increase the dynamic pressure to (0,2 -0/+0,01) MPa [(2,0 -0/+0,10) bar];
7. After pressure adjustment, allow the water to flow for (30 -0/+5) seconds and then record the flow measurement;
8. Repeat at 0.5 bar increments up from 2,0 to 5,0 bar [2,0 2,5 3,0 3,5 4,0 4,5 and 5,0 bar] pressure settings.
9. Calculate the mean flow rate value at the following pressure steps: - 2,0; 2,5; 3,0; 3,5; 4,0; 4,5 and 5,0 bar.

11.2. Requirements

The nominal flow rate shall be defined by the manufacturer at P2 and verified (see *Figure 5*) with 11.1.

For nominal flow rates < 6 l/min: the arithmetic mean value shall be within a tolerance of ± 0.6 l/min of the specified nominal value.

For nominal flow rates ≥ 6 l/min: the arithmetic mean value shall be within a tolerance of $\pm 10\%$ of the specified nominal value.

The verified nominal flow rate plus maximum tolerance shall be listed on the labelling scheme.

Examples:

- Where an aerator is tested and verified to 7.0 L/min it shall be rated as 7.7 L/min(7.0 L/min + 10%)
- Where an aerator is tested and verified to 5.0 L/min it shall be rated as 5.6 L/min(5.0 L/min + 0.6 L/min)

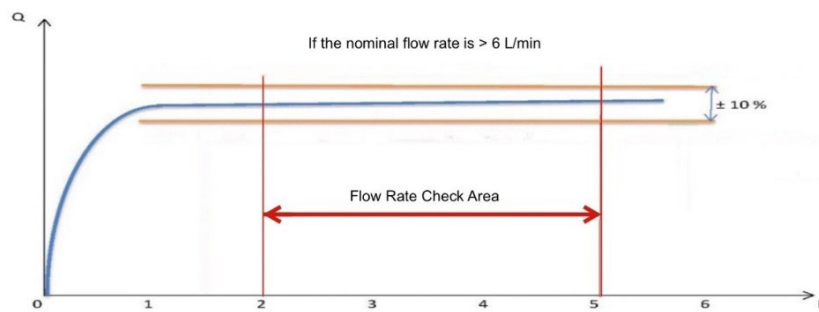
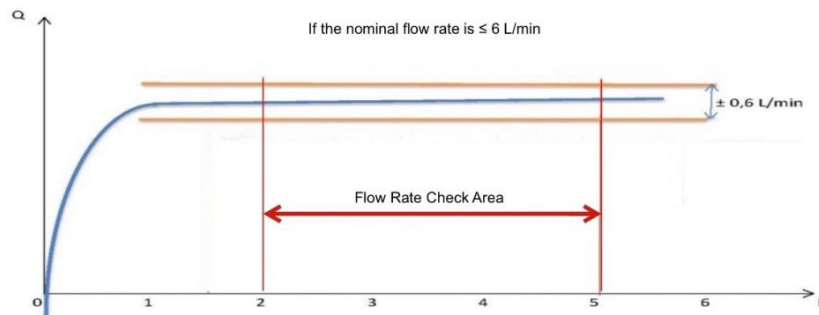

Figure 5: Verification of nominal flow rate of aerators

12. Functional test

12.1. Boost function

The boost function is a water and energy saving feature. It allows for a temporary increase in flow rate that enables the user to more easily undertake a specific action.

12.1.1. Test procedure

1. Connect the product to the test apparatus in its condition of use
2. Apply pressure P2
3. Open the flow control device for the regular use (without boost function)
4. Record the regular flow rate Q_{reg}
5. Activate the boost function
6. Record the flow rate Q_{boost}
7. Close the flow control device
8. Open the flow control device to maximum possible flow without actively using the boost function
9. Record the flow rate Q_{max}

12.1.2. Requirement

The boost function must be auto return to regular flow rate after flow control is turned off. Recorded flow rates shall be $Q_{max} = Q_{reg}$ and $Q_{boost} < 2 Q_{reg}$

The regular flow rate (Q_{reg}) shall be listed on the labelling scheme.

12.2. Cold start

The cold start function is an energy saving feature for single lever, pillar tap and combination tap products

The single lever mixer with the lever in middle position shall only deliver cold water. Middle position is in line with the spout (compare 5).

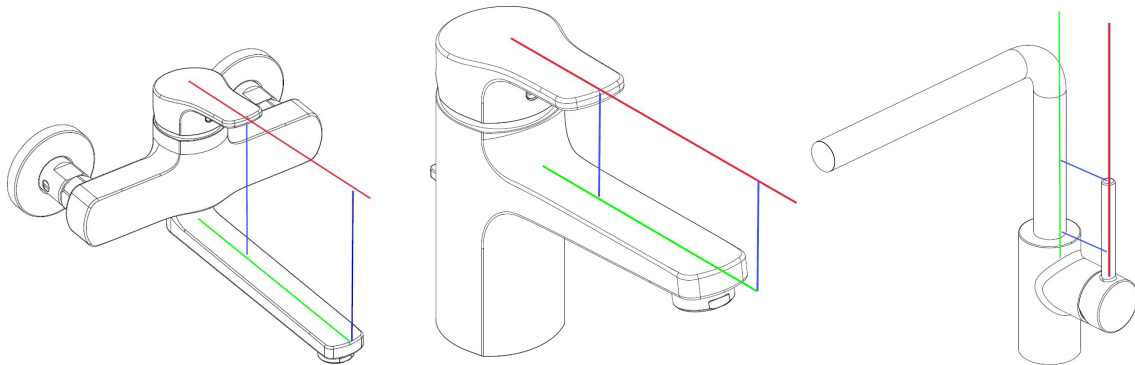

Figure 6: Definition of "middle position"

12.2.1. Test procedure

1. Connect the tap with the cold water inlet to the test apparatus
2. Apply pressure P_2 to the cold water inlet
3. Move the lever to middle position
4. Fully open the flow control device

12.2.2. Requirement

There shall be no leakage at the hot water inlet.

The maximum flow rate (Q_{\max}) shall be listed on the labelling scheme.

The labeled energy shall be $E=0,9 E_{\max}(Q_{\max})$

12.3. Pressure independency

Only applicable for Type 1 products, where the maximum available flow rate $Q_{\max} \leq 8.0$ l/min

12.3.1. Test procedure:

As defined in clause 6, but use reduced pressure P_1 instead of P_2 and record flow rate as Q_{red}

12.3.2. Requirements

The flow rate shall be $Q_{\text{red}} \geq 0,6 Q_{\max}$

12.4. Sensor function

The sensor function is an energy saving feature.

12.4.1. Test procedure

1. Connect the product to the test apparatus in its condition of use
2. Apply pressure P2
3. Open the flow by activating the sensor
4. Record the time after removal of 'hands' to stop the flow
5. Open the flow by activating the sensor
6. Keep sensor activated
7. Record the time to stop the flow

12.4.2. Requirements

Auto off after removal of 'hands' ≤ 2 seconds (pre-set at the factory) Where the sensor is kept activated, run time is ≤ 1 minute

If unit is powered off must auto off for water flow, tested according to EN 15091 paragraph 4.5.5 The maximum flow rate (Q_{\max}) shall be listed on the labelling scheme.

The marked energy shall be $E=0,5 E_{\max}(Q_{\max})$

12.5. Spray Coverage

Applicable for shower outlets, shower solutions and recirculating showers.

Note: The mode used for this test may be different to the one used to determine the maximum available flow rate.

12.5.1. Test – Apparatus

Additionally, to the test apparatus defined in section 4.3, use the annular ring test setup shown in *Figure 7* and *Figure 8*.

In m

General remarks:

- All dimensions in inches. (mm)
- Tolerance: ± 0.06 in. (1.6 mm)
- Suggested Material: (0.03 in. [0.75 mm]) 304 Stainless Steel
- 8 in. – 18 in. Rings Optional (Shown as red dotted lines)

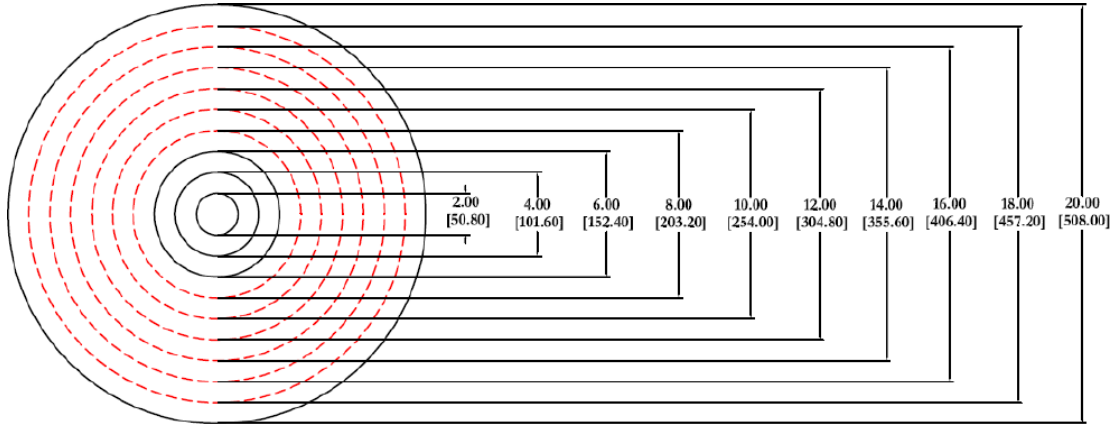

Figure 7: Annual ring specification dimension in inches and (mm)

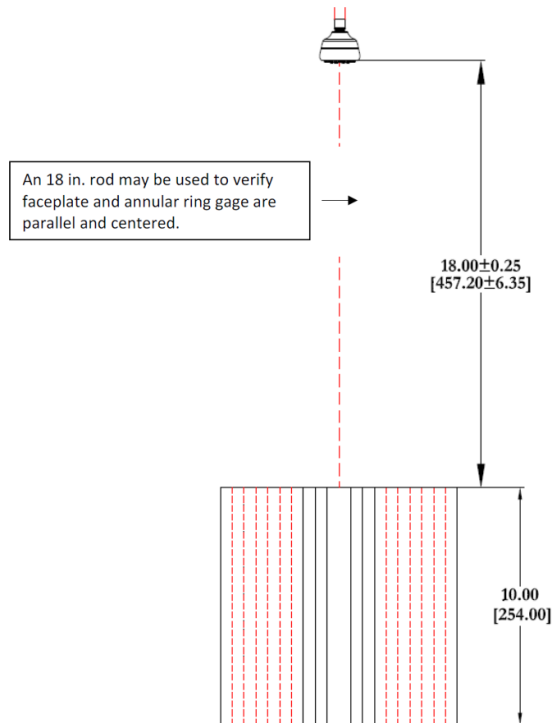

Figure 8: Spray Coverage Test Setup

12.5.2. Test Procedure

1. Connect the shower outlet to the test apparatus
2. Mount the showerhead so the faceplate is horizontal and parallel with the top surface of the annular rings.
3. Position the annular rings underneath the showerhead so the centre line of the faceplate and the centre ring are in vertical alignment and the top of the annular gauge is $(457 \pm 6\text{mm})$ from the faceplate (see *Figure 8*).
4. Apply pressure P2
5. Allow the water to flow through the showerhead and into the annular rings for $(60 +10-0)$ s, if one of the rings is completely filled prior to the end of the time period then stop the flow.
6. Collect, measure, and record the volume of water in each annular ring.
7. Determine the total volume collected in all rings.
8. Calculate and record the percentage of the total recorded volume collected in each ring.

12.5.3. Requirements

The total combined maximum volume of water collected in the two inner annular rings shall not exceed 75 % of the total volume of water collected, and;

The total combined minimum volume of water collected in the three inner annular rings shall not be less than 25 % of the total volume of water collected.

12.6. Spray dripping

Applicable for hand showers.

12.6.1. Procedure

1. Connect the hand shower to the test apparatus
2. Place the hand shower in a 45° angle to a vertical line (see 8)
3. Apply pressure P1 (P2 for Type 2 products)
4. Allow water to flow through the hand shower

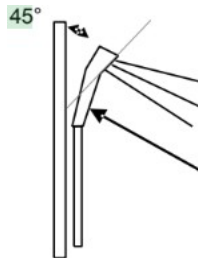

Figure 9: Position of the hand shower

12.6.2. Requirement

No water shall be rinsing along the hand shower when in continuous operation

12.7. Spray pattern

Applicable for shower outlets, shower solutions and recirculating showers.

12.7.1. Procedure

Test according to Clause 5 and observe spray pattern.

12.7.2. Requirement

Spray pattern must be fully developed when in continuous use.

12.8. Thermostatic

The thermostatic function is a technical feature.

12.8.1. Test procedure

According to EN 1111 or EN 1287 chapter 13.4 (Fidelity) and 13.5.2 (Cold supply failure and restoration)

12.8.2. Requirements

According to EN 1111 or EN 1287 chapter 13.4 (Fidelity) and 13.5.2 (Cold supply failure and restoration)
The maximum flow rate (Q_{max}) shall be listed on the labelling scheme.

12.9. Time flow

The time flow function is a water and energy saving feature.

12.9.1. Procedure

1. Connect the product to the test apparatus in its condition of use
2. Apply pressure P_2
3. Activate the product
4. Measure and record flow time t_{flow}

12.9.2. Requirements

The maximum flow rate (Q_{max}) shall be listed on the labelling scheme. The marked energy shall be $E=0,8 E_{max}(Q_{max})$ for taps, if $t_{flow} \leq 7$ seconds
The marked energy shall be $E=0,9 E_{max}(Q_{max})$ for taps, if $t_{flow} \leq 15$ seconds

The marked energy shall be $E=0,9 E_{max}(Q_{max})$ for shower systems, if $t_{flow} \leq 30$ seconds
If $t_{flow} \leq 60$ seconds, the marked energy shall be $E_{max}(Q_{max})$

12.10. Water break

Applicable for taps and shower solutions.

The water break is a water and energy saving feature e.g.

- Hard point to override in open direction
- Push button to allow movement in open direction
- Other mechanical device for flow rate reduction (e.g. spring force in cartridge)

12.10.1. Test procedure

1. Connect the tap to the test apparatus in its condition of use
2. Apply pressure P2
3. Open the flow control device to the water break position
4. Adjust a mixed temperature according to *Table 3*
5. Record the flow rate Q_{red}
6. Fully open the flow control device
7. Measure the override force F (if the tap is equipped with a hard point)
8. Record the flow rate Q_{max}

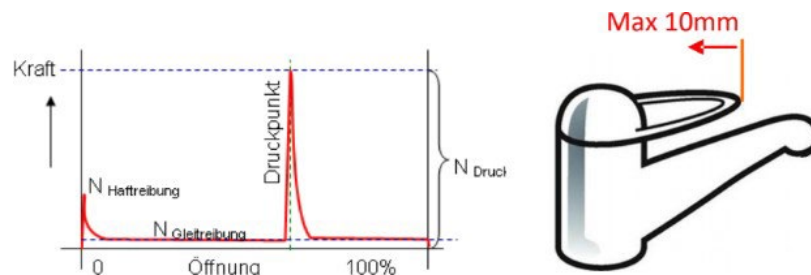

Figure 10: From left to right: graph Force/opening; point of measurement

12.10.2. Requirements

Flow rate in the position of water break, $0,2 Q_{max} \leq Q_{red} \leq 0,6 Q_{max}$ Force to override water break $F \geq 6 \text{ N}$

The reduced flow rate (Q_{red}) shall be listed on the labelling scheme.

